



JORDAN VALVE

3170 Wasson Road • Cincinnati, OH 45209 USA
Phone 513-533-5600 • Fax 513-871-0105
E-Mail: info@richardsind.com • www.jordanvalve.com

I&M 70

Installation & Maintenance Instructions for Mark 70 Multispring Actuator

Warning: Jordan Valve Control Valves must only be used, installed, and repaired in accordance with these Installation & Maintenance Instructions. Observe all applicable public and company codes and regulations. In the event of leakage or other malfunction, call a qualified service person; continued operation may cause system failure or a general hazard. Before servicing any valve, disconnect, shut off, or bypass all pressurized fluid. Before disassembling a valve, be sure to release all spring tension.

Please read these instructions carefully!

Your Jordan Valve product will provide you with long, trouble-free service if it is correctly installed and maintained. Spending a few minutes now reading these instructions can save hours of trouble and downtime later. When making repairs, use only genuine Jordan Valve parts, available for immediate shipment from the factory.

Ideal Installation Schematic

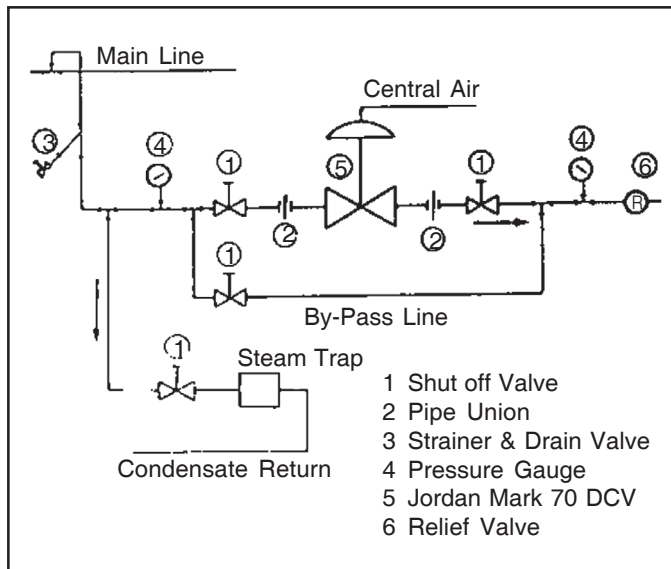

Preferred Installation

1. To protect the valve from grit, scale, thread chips and other foreign matter, ALL pipelines and piping components should be blown out and thoroughly cleaned before the installation process begins.
2. Shutoff valves, pressure gauges and by-pass piping should be installed as indicated in the Ideal Installation Schematic to provide easier adjustment, operation, and testing.
3. A line strainer should be installed on the inlet side of the valve to protect it from grit, scale and other foreign matter. A .033 perforated screen is usually suitable for this purpose. Line strainers are available from Jordan Valve.
4. For best control, 3'-0" straight sections of pipe should be installed on either side of the valve.
5. In preparing threaded pipe connections, care should be

exercised to prevent pipe-sealing compound from getting into the pipelines. Pipe-sealing compound should be used sparingly, leaving the two end threads clean. Jordan uses, and recommends, thread sealer Teflon ribbon

6. The flow arrow on the valve body must be pointed in the direction of flow. Ideally, the valve should be installed in the highest horizontal line of piping to provide drainage for inlet and outlet piping, to prevent water hammer, and to obtain faster response.
7. If possible, install a relief valve downstream from the valve. Set at 15 psi above the control point of the valve.
8. In hot vapor lines, upstream and downstream piping near the valve should be insulated to minimize condensation.
9. In gas service, if the control pressure (downstream) is 25% of the inlet pressure or less, expand the outlet piping at least one pipe size. A standard tapered expander connected to the outlet of the valve is recommended.
10. Where surges are severe, a piping accumulator is recommended.
11. On steam control applications, install a steam trap with sufficient capacity to drain the coil or condenser. Be sure to have a good fall to the trap, and no backpressure. Best control is maintained if the coil or condenser is kept dry.

Trouble Shooting

Trouble	Possible Cause & Cure
Erratic Control	Oversizing causes cycling and hunting and reduces the rangeability of the valve. Make certain that your sizing is correct. Steam traps downstream may need attention. Excessive foreign matter on seats. Clean them. Valve stroke out of adjustment. Check and readjust if necessary. Valve disc may not be moving freely.
Will Not Operate	Diaphragm ruptured. Replace. Range springs broken. Replace. Improper spring setting. Reset.

PROTECT VALVES WITH LINE STRAINERS

Start-Up

1. Be sure that the action of the control valve and of the controller are such as to give the desired results.

CONTROLLER ACTION		
If an increase in pressure or temperature must	And the action of the valve is	Then the action of the controller must be
close valve	air to close	direct
close valve	air to open	reverse
open valve	air to close	reverse
open valve	air to open	direct

2. The control valve has been pre-set by Jordan. However, finer adjustments may be required to compensate for pressure drop conditions of the application. Do not apply more than 45 psi to the actuator.
3. With the inlet, outlet, and by-pass shut-off valves closed, and no pressure in the downstream line, fully open the outlet shutoff valve. Slowly open the inlet valve just enough to start flow through the control valve. Increase flow gradually by slowly opening the inlet shut-off valve. Do not fully open the inlet valve until you are sure that the controller and control valve have control of the system. Usually, the handwheel on the inlet valve will turn freely when this point is reached.
4. To shut off the line fluid, close the inlet shut-off valve first, then the outlet shut-off valve.
5. Body and cap bolts should be retightened per torque procedures after valve reaches operating temperature.

Valve Maintenance

Caution: Make certain that there is no pressure in the valve before loosening any fittings or joints. The following steps are recommended:

1. Close inlet shutoff valve.
2. Allow pressure to bleed off through downstream piping. Do not attempt to reverse the valve by bleeding pressure from the upstream side of the valve.
3. When the pressure gauges indicate that all pressure has been removed from the system, close the outlet shutoff valve, and the valve may be serviced.

Note: refer to the drawing at the end of this document for description and proper orientation of parts.

Valve Seats

A. DISASSEMBLY

The valve seats in all Jordan regulators are lapped to a light band flatness. Maintaining such tolerances is of paramount importance for your assurance of excellent control and tight shut-off. Do not use metallic objects in removing the seats. Care in handling is imperative.

1. Close the shutoff valve on each side of the valve, and remove valve from line.
2. Note scribed "<" on the side of the valve body (1) and cap (2). Secure the body outlet flat in a vise. Remove the cap screws and two nuts, and lift the cap straight up.

3. Before removing, check the disc (5) for a stamped arrow. This arrow points to the "<" on the body. Remove the disc guide and the disc. Place the valve disc on the bench with lapped surface facing up. Protect the lapped surface on both sides of the disc guide.

IMPROPER HANDLING OF SEATS WILL RESULT IN LEAKAGE OR POOR CONTROL.

It is imperative that the disc pin not be rotated when disassembling, cleaning, or reassembling, since this affects the stroke adjustment.

4. Lightly tap on the body to remove the plate (4). Invert the body, let valve plate drop out into your hand, and place it on the bench with lapped surface facing up.
5. Clean all the parts, body, and cap with solvent. Place a piece of 4/0 polishing cloth or jewelers cloth on a smooth, flat surface such as a surface plate, and polish the disc, plate, and disc guide lapped seating surfaces using a "figure 8" motion. If the parts are scarred, do not attempt to relap them, but return them to the factory for repair and replacement. If the seats are not scarred deeply, they can be repaired at nominal cost.
6. The vertical sections of the disc guide serve as guides for the disc while stroking. A 0.005" feeler gauge should be used to check for clearance between this surface and the side of the disc. If the clearance is less, clean the guide surfaces in the disc guide with a fine file.

B. REASSEMBLY

1. Place the plate in the body, lapped surface facing the cap. The index pin hole should be on the same side as the "<" on the body. Align the disc pin so that it is centered in the body bore and protrudes through the center slot in the valve plate (unless you are changing the valve action - See Section on Changing Valve Action.)
2. Place the disc on the plate, engaging the disc pin. If there is an arrow on the disc, it should point toward the index pin hole on the plate.
3. Place the disc guide onto the plate, engaging the index pin. Rotate the assembly slightly until the slot openings in the disc are parallel to the opening in the plate, and perpendicular to the stem. Stroking the valve will aid in this alignment.
4. Align the ">" on the cap with the "<" on the body, and place the cap over the two studs in the body.
5. Install the nuts and cap screws. Tighten uniformly. See back page for torque requirements and tightening procedures.

Stem, Disc & Pin Replacement

1. Remove disc and plate following the procedure outlined under *Valve Seats*.
2. Loosen stem connector nut (22) and bolt (21) and remove connector (20).
3. Back out the four allen head yoke screws (19) (1/2" - 2" sizes) which will allow the body to be separated from the yoke.
4. Remove the packing flange nuts (17) and the packing flange (12).
5. Loosen the stem locknut (9) and rotate the disc pin (8) counterclockwise, pulling the valve stem (10) upward while doing so.
6. When pulling the stem completely out of the body you will remove most of the packing assembly (11) also. The remaining parts of the packing assembly can "fished" out with a small screw driver.
7. Clean the packing bore in the body with solvent and blow dry.

8. The disc-pin may be removed through the body bore.
9. Clean the stem and disc-pin with solvent if they are to be reused.
10. Reassemble the disc-pin, stem and locknut in the valve body as they originally were.
11. Replace the packing spring (15) and packing retainer (14) in the packing bore.
12. Reassemble the new packing (11) on the stem with the open part of the "V" downward (^). There will be a flat on the top and bottom. Place the packing follower on top of the packing.
13. Gently push the packing into the packing bore and place the packing flange on the stem and over the packing studs.
14. Put on the flange nuts and tighten them partially. At this point it is recommended that you gently move the stem up and down three or four times to align the assembly.
15. Tighten the flange nuts until the packing follower bottoms out on the top of the body.
16. Replace actuator in reverse order. Reassemble the valve by inserting seats as outlined in Valve Assembly Section for the size valve you are working with. Then follow the instruction for seat alignment.

ACTUATOR

CAUTION: Do not apply more than 45 psi to actuator.

The valve need not be removed from the line; however before performing any maintenance on the actuator.

- a. Shut off the control air supply and remove the line from the actuator.
- b. Remove stem connector (20) by loosening nut (22) and bolt (21).

A. Actuator Disassembly

1. Remove the actuator assembly from the valve by removing the four bolts (24) and lifting the actuator off of the yoke.
2. Remove spring compression by threading the actuator stem (23) out of the actuator.
3. Remove the actuator case bolts and nuts (28, 29) and lift the upper actuator case (27) off of the lower actuator case (26)
4. Turn the actuator bolt (35) completely out of the actuator stem (23) and lift the diaphragm assembly out of the actuator case.
5. Loosen and remove the two lock nuts (36). Remove the diaphragm plate (33) and diaphragm (31) from the actuator bolt (35).
6. Clean all parts with a good quality solvent. Remove encrusted material with crocus or very fine aluminum oxide cloth. Inspect all parts for excessive wear and/or damage. Replace worn or damaged parts. **USE ONLY JORDAN REPLACEMENT PARTS.** The use of other than genuine JORDAN parts may impair their ability to serve you.

B. Actuator Reassembly

1. Assemble the diaphragm stop (32), diaphragm (31), and diaphragm plate (33) to the actuator bolt (35). Align the diaphragm and diaphragm plate such that one of the formed bosses on the diaphragm plate is lined-up with one of the bolt holes in the diaphragm. Assemble and tighten the two locknuts (36) taking care that they are locked together, and that the alignment between the diaphragm plate is maintained.
2. Place the diaphragm assembly (from step 1) on the upper actuator case (27) with the diaphragm plate up. Place the six springs (34) on the diaphragm plate so that they nest over the formed bosses. Assemble the lower case so that the six bolts (30) nest in the springs. Springs must also remain nested over the bosses in the diaphragm plate.

3. Replace four of the actuator case bolts and nuts (28, 29) at 90° and tighten finger-tight. Replace the remaining bolts and nuts and tighten evenly across the actuator case.
4. Thread the actuator stem onto the actuator bolt until the shoulder on the stem contacts the adapter plate (25).
5. Reassemble the actuator assembly to the valve yoke (18) using the four screws (24).
6. Reconnect the actuator stem to the valve stem (10) using the stem connector and its bolt and nut.
7. Adjust the spring preload. (See Spring Adjustment)

VALVE STROKE ADJUSTMENT

1. Loosen the stem connector nut (22) only enough to allow the stem adapter (38) to rotate. **DO NOT REMOVE** the stem connector (20). Proper positioning of the valve stem (10) and the stem adapter (38) must be maintained while adjusting the seats.
 - 2A. For Direct Acting (Air-to-Close) Valve
Thread the actuator stem (23) on the actuator bolt (35) until the springs (34) are slightly compressed. This insures that the actuator stem is in its fully upward position. To confirm that the actuator stem is fully stroked up, check that it cannot be rotated easily without a wrench.
 - 2B. For Reverse Acting (Air-to-Open) Valves
Apply an air pressure of approximately 5 psi above the maximum range pressure (ex. 20 psi for 3-15 psi range) to the actuator. This strokes the actuator stem (23) fully down. To confirm that the actuator stem is stroked fully down, check that it cannot be easily rotated without a wrench.
3. Check the alignment of the orifices in the disc and plate. The orifices must be in the open position and in perfect alignment. If the orifices are not in proper alignment, loosen the locknut (37) and thread the stem adapter (38) into, or out of, the actuator stem (23) which will move the disc (5) up, or down, on the plate (4).
4. After proper alignment has been obtained, tighten the locknut (37) against the end of the actuator stem (23). Recheck the seat adjustment.
5. Adjust spring preload if necessary. See **SPRING ADJUSTMENT**.

Spring Adjustment

The signal range is preset by JORDAN; however, when the valve is installed this range may shift slightly due to pressure drops across the valve. Additionally, preload adjustment may be required after one of the previous maintenance procedures. Note: ATO 3-15 psig rated valves are bench set at factory at 5-17 psig. Please insure that any I/P utilized with this control valve is capable of 17 psig output to ensure full valve travel. If desired, the range may be changed to suit your needs by following the instructions below.

1. Remove the air signal line from the actuator and replace with a pressure gauge and an air regulator.
2. Loosen, but do not remove, the stem connector bolt and nut (21, 22).
3. Adjust the actuator air pressure to just below the starting point of the range and rotate the actuator stem (23) until the stem just starts to move. Continue to rotate the actuator stem about one-half turn. Remove the air pressure. Increase the air pressure and check the pressure at which the valve just starts to move. Repeat actuator stem adjustment if necessary and again check pressure at which the stem starts to move.
4. After the preload has been properly adjusted, tighten the stem connector bolt and nut, and reattach the control air line.

1/4" -2" Mark 70 Control Valves With Multispring Actuators

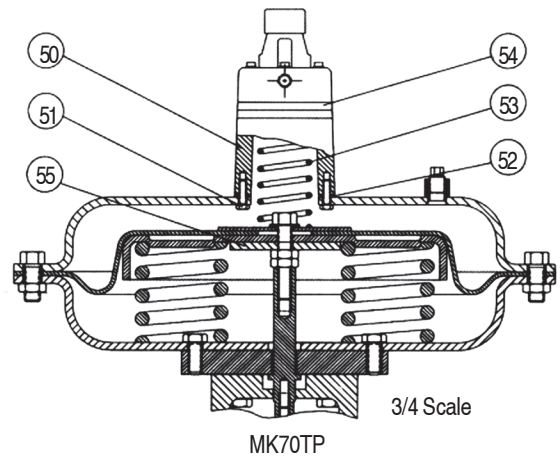
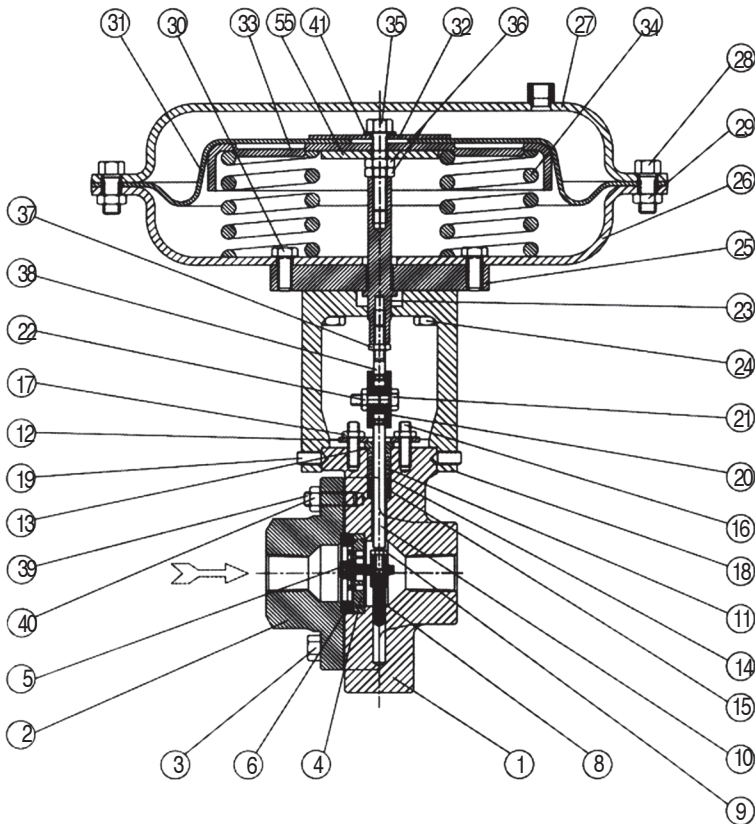

TORQUE FOR BOLTS (3) CONNECTING VALVE CAP TO VALVE BODY (in. - lbs.)

Valve Size	Valve Body Material	
	Bronze	Ductile Iron, Cast Steel Stainless Steel
1/2" & 3/4"	140	200
1" & 1-1/4"	140	200
1-1/2" & 2"	140	200

Changing Valve Action

The action of a Sliding-Gate valve may be changed from DIRECT ACTING to REVERSE ACTING, or vice versa, by rotating the disc (5), plate (4), and valve cap (2) 180°. Check the valve stroke and orifice alignment and adjust, if required, as outlined in VALVE STROKE ADJUSTMENT.

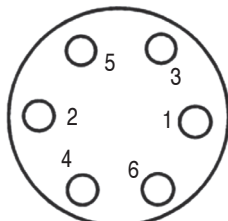

6 Bolts (or multiples)

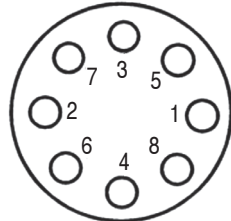

8 Bolts (or multiples)

Item	Description	Item	Description
1	Body	25	Adapter Plate
2	Cap	26	Lower Actuator Case
3	Bolt (Body Cap)	27	Upper Actuator Case
4	Plate	28	Actuator Case Bolt
5	Disc	29	Adapter Case Nut
6	Disc Guide	30	Adapter Plate - Actuator Bolt
8	Disc Pin	31	Diaphragm
9	Stem Locknut	32	Diaphragm Stop
10	Stem	33	Diaphragm Plate
11	Packing	34	Spring
12	Packing Flange	35	Bolt
13	Packing Follower	36	Locknut
14	Packing Retainer	37	Actuator Stem Locknut
15	Packing Spring	38	Stem Adapter
16	Packing Stud	39	Stud
17	Packing Nut	40	Nut
18	Yoke	41	Seal Washer
19	Yoke Screw	50	Position Adapter Ring
20	Stem Connector	51	Positioner Screw
21	Stem Connector Bolt	52	Positioner Gasket
22	Stem Connector Nut	53	Positioner Spring
23	Actuator Stem	54	Positioner
24	Adapter Plate Bolt	55	Backing Plate (85M)

WHEN ORDERING SPARE PART, SPECIFY:

1. Valve serial number
2. Type of valve (PRV, TCV, DCV, etc.)
3. Body size and material
4. End connection (if flanged, give rating)
5. Spring range
6. Refer to parts list above and specify part number and name.

3170 Wasson Road • Cincinnati, OH 45209

Phone 513-533-5600 • Fax 513-871-0105

Phone Toll-Free: 800-543-7311 (USA)

E-Mail: info@richardsind.com

URL: www.jordanvalve.com

